

Power Gate Assembly Instructions

SAFETY NOTICE

Thank you for purchasing a Power Gate kit. This kit is intended to be assembled and used by licensed Amateur Radio Operators who are skilled and knowledgeable in the art. All inputs and outputs to the Power Gate must be properly protected by fuses, circuit breakers or other means to limit currents to safe levels. Installing these protection devices is the responsibility of the user. Specifically, all DC current sources (batteries, power supplies) and all DC loads (station equipment) must be protected by in-line current limiting devices external to the Power Gate. If you are uncomfortable with your ability to safely operate the Power Gate, please return the unassembled kit for a full refund.

INTRODUCTION

The Power Gate allows you to run your station with fulltime, instantaneous power backup. A pair of Schottky diodes operate as an electronic gate to connect either of two power supplies to your rig. Usually one supply will be your normal AC connected station power supply and the other a backup battery. Switching is completely automatic in both directions; the source with the highest DC voltage will be connected automatically to your rig.

Think of the possibilities:

- Continuous operation during intermittent storm power outages.
- Temporary emergency battery operation while the backup generator is being started.
- Long-term operation from a large battery bank with a standby DC power supply.
- Field Day operation with both an AC generator and batteries.
- RV or camping operation with both an AC generator and batteries.
- Operation from two separate battery banks.
- Operation from two separate DC power supplies.

SPECIFICATIONS

- DC Load: 20 Amps continuous, 40 Amps at 50% duty cycle.
- Input voltage: 0 – 15 Volts DC from two sources
- Forward Voltage Drop: 0.4 Volts or less at 20 Amps load
- Maximum Reverse Voltage: 20 Volts
- Input and Output Connections: 45 Amp Anderson Power Poles with 10 gauge wire

TOOL REQUIREMENTS

The assembly is straightforward and will be described in detail below. Before you begin you will need to gather the following tools:

- Soldering iron of at least 60 watts capacity (preferably greater) for tinning and soldering the #10 wires
- Rosin core solder

- Solder flux, liquid or paste, to aid in tinning and soldering the #10 and #12 wires
- Small vise or “helping hands” to hold parts during assembly
- Sharp utility knife
- drill bit, 1/4” or larger, for de-burring heatsink holes
- Ruler for measuring insulation strip lengths
- Small nose pliers
- Large wire cutter
- Small slotted screw driver
- Medium slotted screw driver
- 5/16 inch nut driver or small wrench
- hot air gun or other source of heat for shrinking tubing
- Crimping tool for 45 amp Anderson Power Pole terminals. If you do not have this tool, please arrange to borrow one from the club or a friend. DO NOT attempt to crimp these terminals with other tools! Note: upon request these terminals can be preinstalled. If a crimping tool is not available, 30 amp terminals may be substituted and soldered rather than crimped.

PARTS LIST

Quantity	Description
1	Common Cathode Schottky Diode Package – Vishay 80CPQ020PbF
1	Heat Sink
1	Thermal Pad
3	#10 Red/Black Cables, 6” long
1	#12 Red wire, 3” long
1	Nylon Wire Tie
3	Anderson Power Pole 45 Amp Kits - shells, contacts, roll pins
1	3 Pole Terminal Block
1	Large Black Heat Shrink Tube
1	Small Black Heat Shrink Tube
3	#6x32 3/4” Screws
3	#6x32 Nuts
1	#6 Flat Washer
1	#6 Toothed Lock Washer
3	Printed Wire Labels

ASSEMBLY INSTRUCTIONS

Refer to Figure 1. Orient red and black Power Pole connector shells so that the ends look exactly as shown in Figure 1. Slide the shells together with the raised part of one shell fitting in the depression in the other until the ends are aligned. Press the locking pin into the hole between the shells. Likewise assemble the remaining shells.

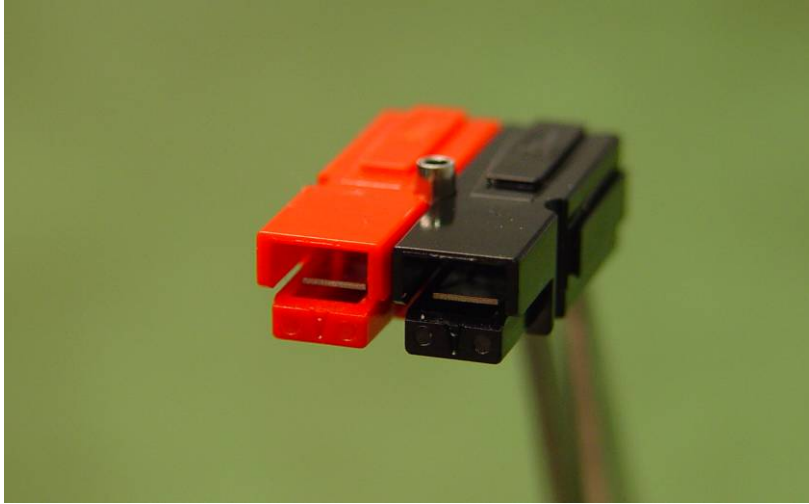

Figure 1

Refer to Figure 2. Prepare one end of each of the three #10 red/black wire pairs. Ensure the wire pair ends are squarely cut. If not, square the cut with your wire cutter. Separate the black and red wires approximately 1" at the ends where the Power Pole connectors will be installed. Strip 5/16" of insulation from each wire. Take care not to cut or nick the wire strands. Twist the strands to keep them together.



Figure 2

Refer to Figures 3 and 4. Note the orientation of the Power Pole terminals on the black and red wires in Figure 3. The terminals must be installed with this orientation. With the orientation clearly in mind insert a terminal into the 45 amp die of the crimping tool. Take care that the terminal “wings” are properly oriented and in line with the upper die. Now fully insert one of the wires into the terminal and close the handles of the tool until it releases, completing the crimp. Inspect the crimped terminal to ensure it is oriented as shown in Figure 3 and correctly crimped. Crimp another terminal on the second wire of the pair.



Figure 3



Figure 4

Refer to Figure 5. Orient the connector shells and terminals as shown in the figure. Slide the wires and terminals into the connector shells until each contact locks over the end of the internal spring. You will hear and/or feel a “click” when this happens. Inspect the open ends of the connectors to ensure the terminals have locked over the ends of the internal springs.

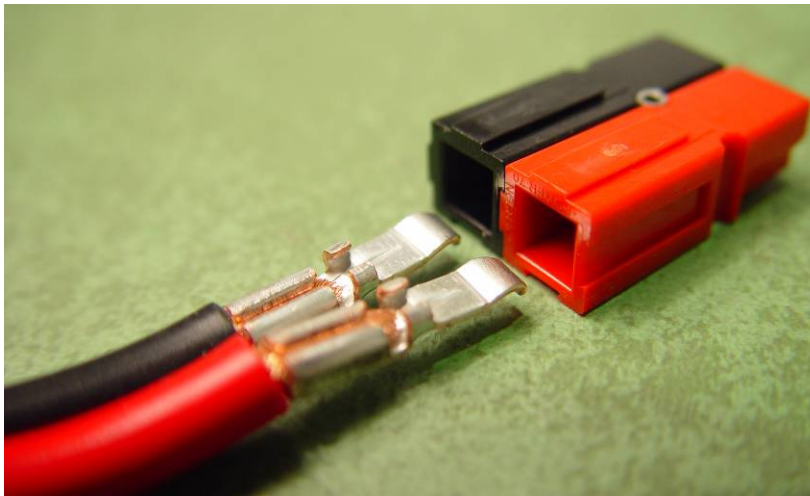

Figure 5

Crimp terminals on the remaining two red/black wire pairs and insert the terminals into their shells.

Refer to Figure 6. On the opposite ends of the red and black wire pairs separate the wires approximately 1-1/4". Strip 3/8" from each red wire and 5/8" from each black wire. Take care not to cut or nick the wire strands. Apply flux to the red wire ends only, twist the strands tightly and tin each red wire. Leave the black wire ends bare for now.

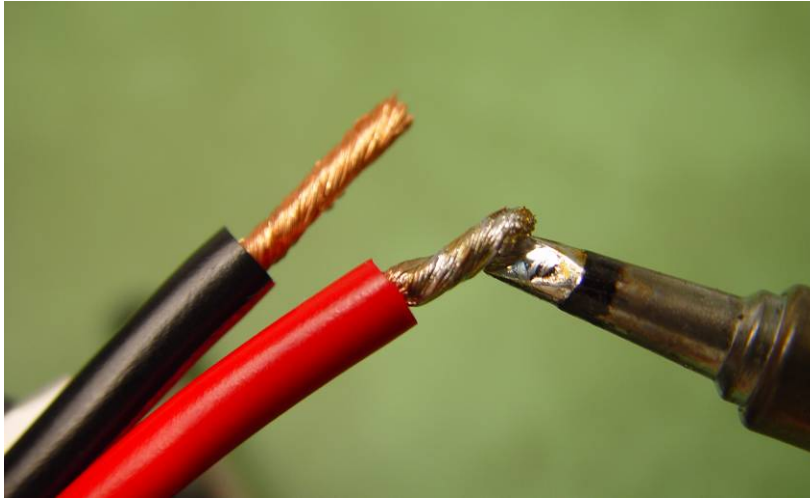

Figure 6

Refer to Figure 7. Install the red tinned ends of the three wires into the terminal block and tighten the screws securely. Secure the three wires together with the black cable tie close to the terminal block. Apply flux to the three black wire ends and twist the three ends tightly together. Solder this connection. Slide the large black heat shrink tubing over this connection and shrink it using your heat source.



Figure 7

Refer to Figure 8. Using your small nose pliers, bend the leads of the Schottky diode package as shown in the figure. These bends allow the bottom of the diode package to fit flush with the bottom of the terminal block. Note the center lead is bent to a 90 degree angle while the outer leads are bent to approximately a 30 degree angle and then flattened. Test fit the diode package and the terminal block to ensure the bends are correct. You may need to clip the ends of the outer leads slightly to allow the diode package to be fully inserted into the terminal block.

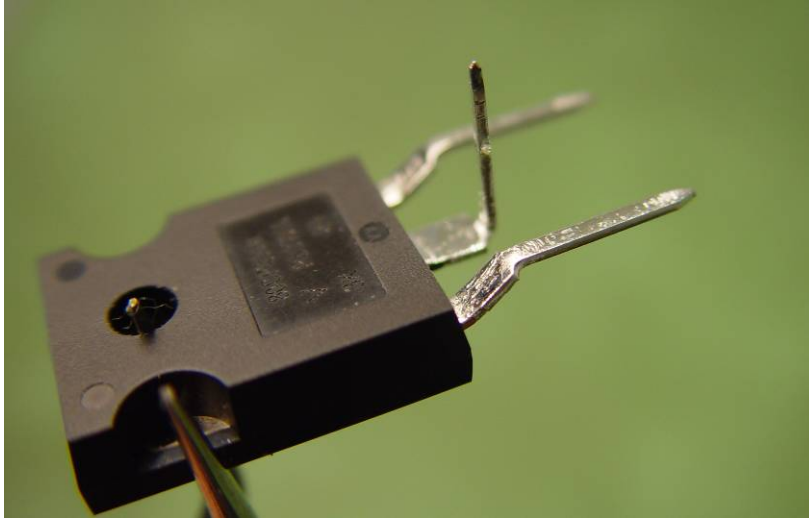

Figure 8

Refer to Figure 9. Strip 3/8" from each end of the short red wire and apply flux to both ends. Tin one end. Solder the other end to the center terminal of the diode package. Be careful to not apply heat for more time than necessary. Slide the small heat shrink tubing over this connection and shrink it using your heat source.

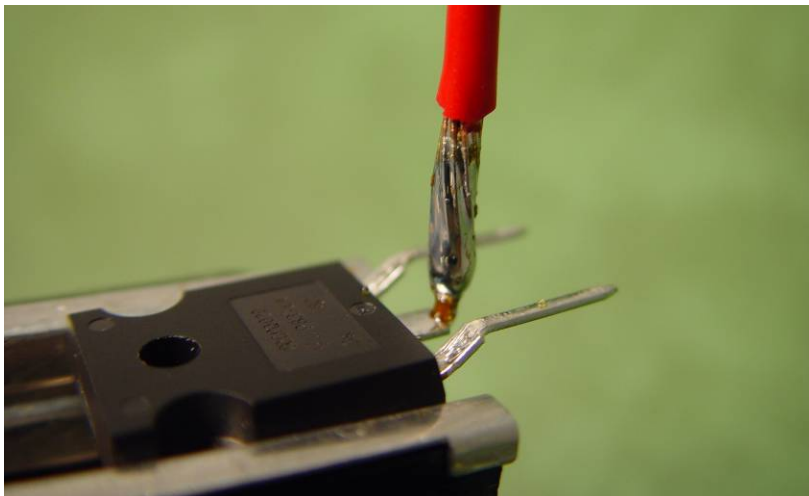

Figure 9

Refer to Figure 10. Install the diode package onto the terminal block as shown in the figure. Bend the red wire to fit into the third terminal of the terminal block. Check to be sure the bottom of the diode package is flush with the bottom of the terminal block with a gap of about 1/8" between them. Tighten all three screws securely.

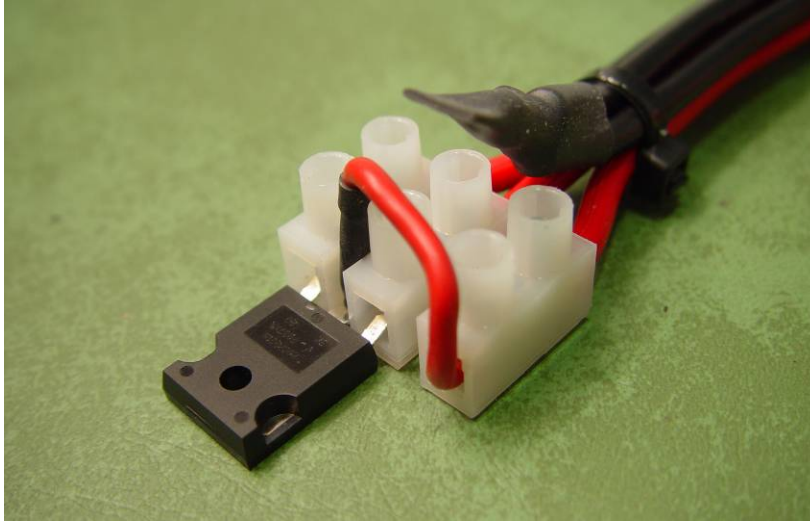

Figure 10

Refer to Figure 11. Remove the protective cover from the adhesive side of the beige-colored thermal pad. Position the adhesive side of the pad over the bottom of the diode package so that the holes in the package and thermal pad are aligned. Press the pad so that it sticks to the diode package.

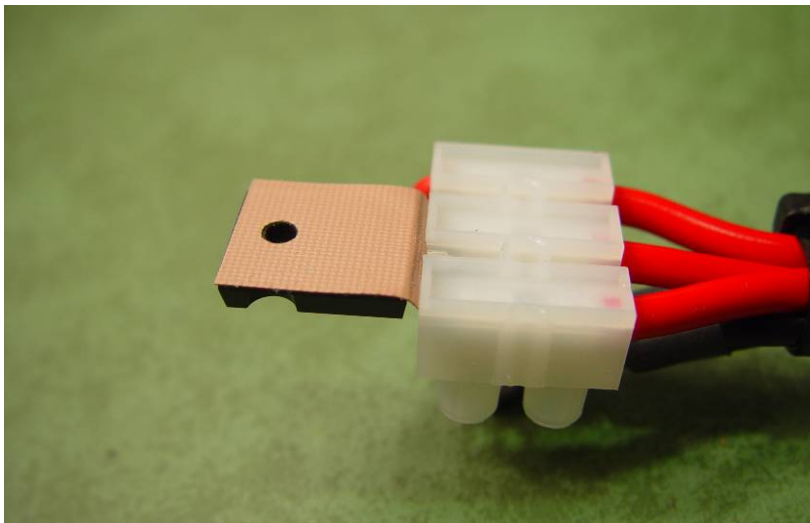

Figure 11

Refer to Figure 12. Using a drill bit, deburr the three holes in the heatsink. Position the cable/terminal block/diode assembly over the predrilled holes in the heatsink. Insert two #6x32-3/4" screws from the bottom of the heatsink through the terminal block and secure loosely with #6 nuts. Check the alignment of the heatsink and diode mounting holes. If they can not be

aligned by shifting the total assembly, loosen the terminal block screws holding the two outer diode terminals and move the diode in or out as necessary to align the diode/heatsink holes. Insert a #6x32-3/4" screw from the bottom of the heatsink through the diode package. Place a #6 flat washer, a #6 toothed lock washer and finally a #6x32 nut on the screw. Tighten the nut very snugly, without over-tightening. The objective is to ensure a very good thermal connection between the diode and the heatsink. Finally, snugly tighten the screws holding the terminal block and the recheck the snugness of the screws holding each wire.

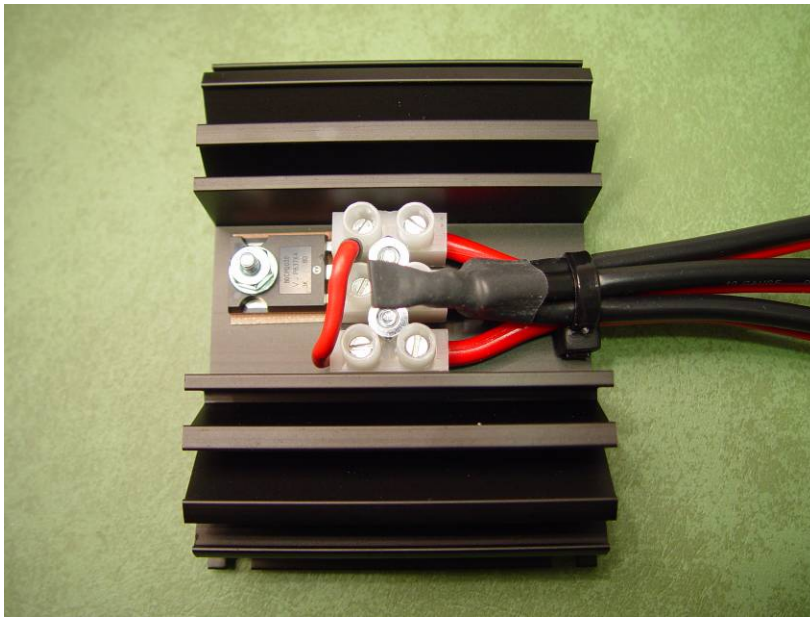

Figure 12

Refer to Figure 13. Attach the adhesive wire labels as shown in the figure.

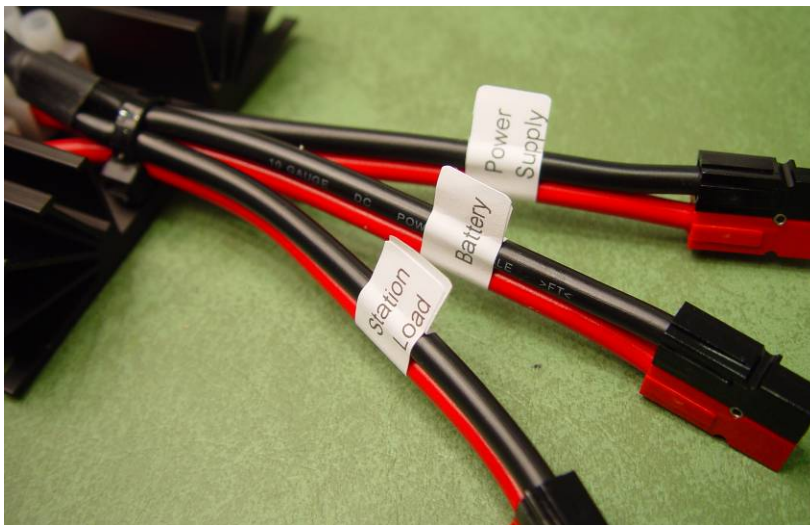

Figure 13

OPTIONAL FLOAT CHARGE RESISTOR

A traditional battery charger can be used to charge and maintain the battery. However, if left attached to the battery continuously, it should be capable of automatically switching to a safe float charge setting. As an alternative, a single resistor can be added to the Power Gate to provide a slow recovery and float charge circuit fed by the station power supply.

Refer to Figures 14a and 14b. An optional resistor may be installed to provide a float charge current to a battery connected to one of the inputs. Generally six-cell Lead-Acid batteries should be float charged at between 13.5 and 13.8 volts with a float current of 0.005C. For specific information on your battery refer to the manufacturer's data sheet. Caution: Maintaining the float voltage within the specified range is very important for optimum battery life. The resistor is connected between the output load terminal and the battery terminal. It must be sized to reduce the voltage from the Power Gate output to a value between 13.5 and 13.8 volts while limiting the float current to 0.005C. Furthermore, the power rating of the resistor must be able to handle the current flow when the battery is fully discharged, perhaps as low as 10 volts. Refer also to the schematic in Figure 15 to see the placement of this resistor.



Figure 14a



Figure 14b

The pertinent formulas for calculating the value of the resistor are below. The table immediately below lists several values for common configurations of 7 amp-hour sealed lead-acid batteries with a power supply voltage between 13.8 and 14.0 volts. To be safe you should check your power supply voltage and the float voltage and current on your battery bank and adjust these values as needed. The 1.25 ohm, 20 watt resistor can also be used on larger capacity batteries recognizing that the total charge recovery time after a discharge will be longer.

Number of 7 amp-hour batteries in parallel	Float Resistor Values
1	5 ohms, 5 watts
2	2.5 ohms 10 watts
4	1.25 ohm, 20 watts

$$\text{Float Resistor} = \frac{\text{Supply Voltage} - \text{Diode Forward Voltage} - \text{Float Voltage}}{0.005 \times C \text{ (i.e. battery amp - hr rating)}}$$

$$\text{Float Resistor Power} = \left(\frac{\text{Supply Voltage} - \text{Diode Forward Voltage} - \text{Discharge Voltage}}{\text{Float Resistor}} \right)^2 \times \text{Float Resistor}$$

For example:

Supply Voltage = 14.0

Diode Forward Voltage ~ 0.25 (at < 0.5 amps)

Float Voltage = 13.6

Discharge Voltage = 10.0

Battery C = 7.0

$$\text{Float Resistor} = \left(\frac{14.0 - 0.25 - 13.6}{0.005 \times 7} \right) = 4.3 \text{ ohms}$$

$$\text{Float Resistor Power} = \left(\frac{14.0 - 0.25 - 10.0}{4.3} \right)^2 \times 10 = 3.3 \text{ watts}$$

THEORY OF OPERATION

The Power Gate's primary electronic component is a pair of Schottky diodes, D1 and D2, connected in a common cathode configuration as shown in Figure 15. Schottky diodes have a lower forward voltage than conventional silicon or germanium devices and are therefore useful in low voltage circuits where low voltage drop and low power loss are desired. Schottky diodes with forward voltages of 0.4 volts or less under load are available. The schematic below includes two DC power sources: a conventional 13.8 volt DC power supply and a 12 volt battery. The load can be any device that requires a nominal 12 volts DC supply.

The Schottky diodes act as an electronic switch. The power source with the higher voltage will cause its diode to conduct current while biasing the opposite diode into non-conduction. If the voltage of that source falls below the voltage of the opposite source, conduction will shift to the opposite diode and its source. The optional resistor R connecting the output load terminal to the battery acts as a path for current to charge and maintain the battery at its nominal float voltage level. This resistor must be carefully selected to ensure that the float voltage and current do not exceed 13.8 volts and 0.01C for lead-acid batteries.

Note: If your station has equipment that does not have a power on/off switch, you should consider the addition of a Master Switch. Otherwise, when you shut down your station including the AC connected power supply, those devices will continue to draw power from the backup battery. This could also happen if you are away from home when a power failure occurs while your station is powered up.

SCHEMATIC

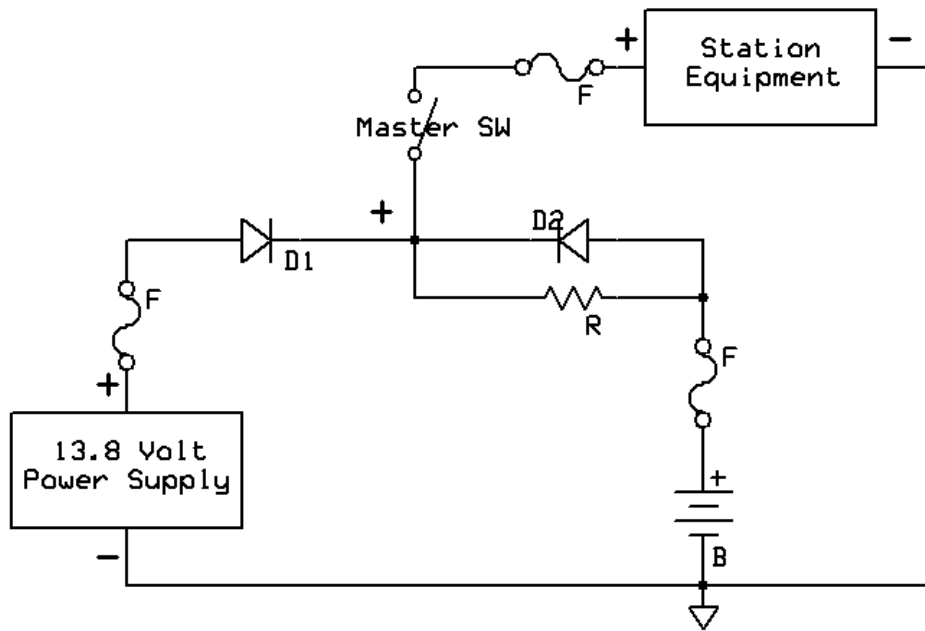

Figure 15

Please refer comments on these assembly instructions to ae4cw@nfarl.org.